

DETAIL A  
SCALE 5 : 1

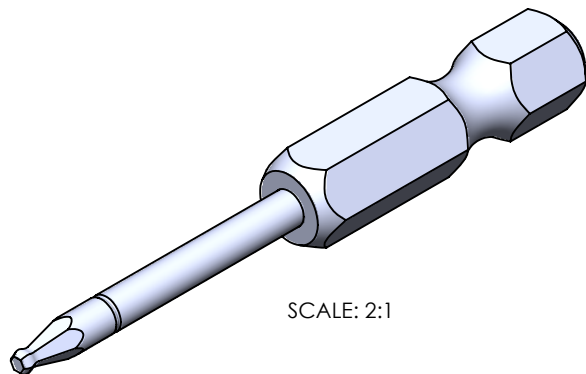

SCALE: 2:1

UNLESS OTHERWISE SPECIFIED: DIMENSIONS ARE IN INCHES			TOLERANCES: X.XX= ±0.13 X.XXX= ±0.015 X.XXXX= -0.0010		
DRAWN	NAME	SIGN	DATE		
APP'VD	A.T.		01.21.19		
MATERIAL: SHAFT: 465 MAGNETIC S.S. HEX BIT: 316 NON-MAGNETIC S.S. WELD: 316 NON-MAGNETIC S.S.					TITLE: 1.5MM BALL X 2.00" OAL, 1/4" POWER HEX BIT
THIS DRAWING IS THE PROPERTY OF STERITOOL, INC. ANY REPRODUCTIONS OR MODIFICATIONS OF THIS DRAWING OR ITS CONTENTS WITHOUT THE CONSENT OF STERITOOL, INC. IS PROHIBITED.					PART NO. 13064
					SCALE: 3:1